

Linea Narrow Leaning Bookcase

Assembly Instructions

Please read all of the information below before you begin.

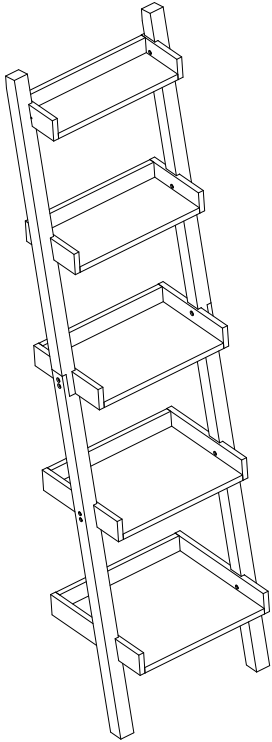

Thank you for purchasing the Linea Narrow Leaning Bookcase. The contents included in the box are listed below and on the next page. Please take the time to identify the hardware and bookcase. As you unpack and prepare for assembly, place the contents on a carpeted or padded surface to protect them from damage.

Required Assembly Tools	 Drill & 17/64" Drill Bit	 Hammer or Mallet
	 Phillips Screwdriver	

Use a mallet or hammer to tap the dowels into place. A Phillips screwdriver, drill and 17/64" drill bit are required to complete assembly of the anti-tip wall strap.

Hardware	
(H1) x 4+1 extra	long dowel
(H2) x 8+1 extra	short bolt
(H3) x 2+1 extra	binding screw
(H4) x 2+1 extra	long bolt
(H5) x 8+1 extra	short dowel
(H6) x 2	Allen wrench
(H7) x 2	mending plate
(H8) x 4+1 extra	flathead screw
(H9) x 2	support bracket
(H10) x 8+1 extra	pan head screw
Anti-Tip Hardware	
(H11) x 1	38mm wall screw
(H12) x 1	wall anchor
(H13) x 1	pan head screw
(H14) x 1	wall strap

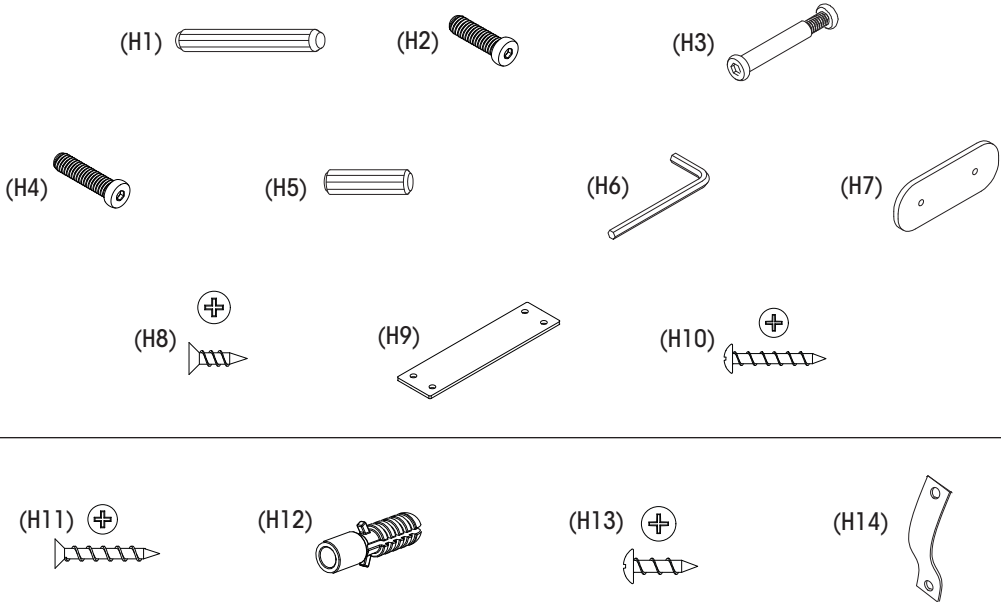

WARNING — Severe injury may occur if furniture tips over. Never allow children to climb or play on this product. Place heavier items on lower shelves as far back as possible and never overload. Follow all instructions listed in this assembly guide and always use the anti-tip hardware to mount unit to a wall.

Item Description	Quantity
A. Right Upper Leg	1
B. Right Lower Leg	1
C. Left Upper Leg	1
D. Left Lower Leg	1
E. Top Shelf	1
F. Second Shelf	1
G. Third Shelf	1
H. Fourth Shelf	1
I. Bottom Shelf	1

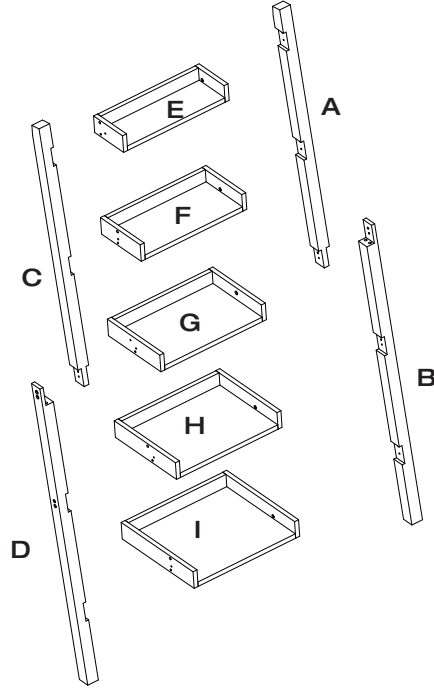

Step 1

(H1) x 4+1 long dowel

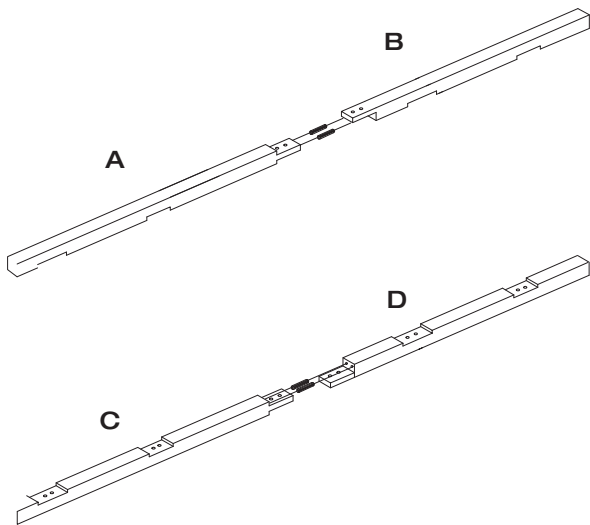

1. Use two long dowels (H1) to join the leg pieces as shown.
2. Make sure the dowels are fully inserted.

Step 2

(H2) x 4 short bolt

(H4) x 1 long bolt

(H3) x 1 binding screw

(H5) x 4 short dowel

(H6) x 2 Allen wrench

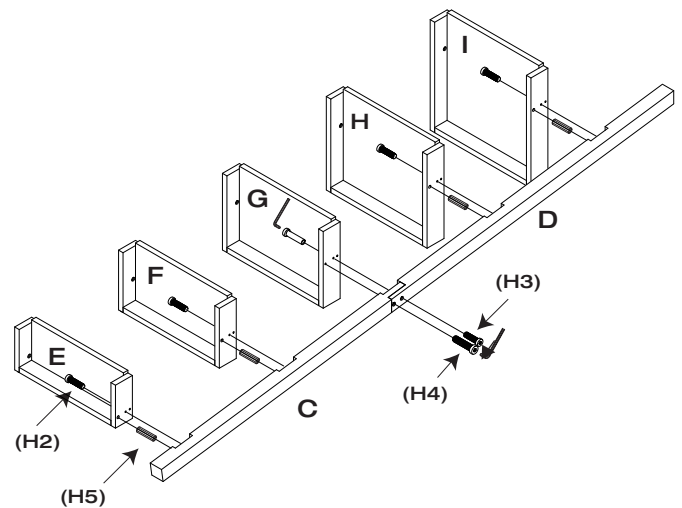

1. Fasten the Third Shelf (G) to the leg assembly (C+D) using a long bolt (H4) and a binding screw (H3).
2. Attach the remaining shelves using a short bolt (H2) and a short dowel (H5).

Step 3

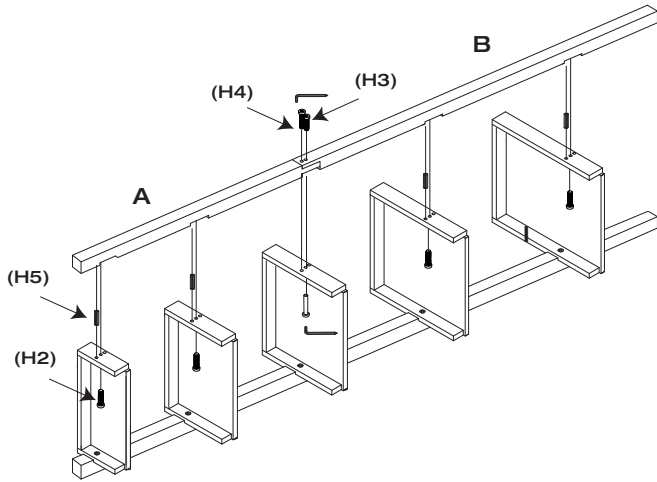
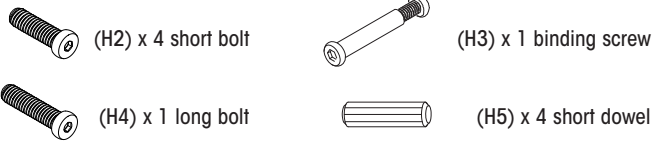

1. Fasten the right leg assembly (A+B) to the Third Shelf (G) using a long bolt (H4) and binding screw (H3).
2. Use the short bolts (H2) and short dowels (H5) to fasten the right leg assembly to the remaining shelves.

Step 4

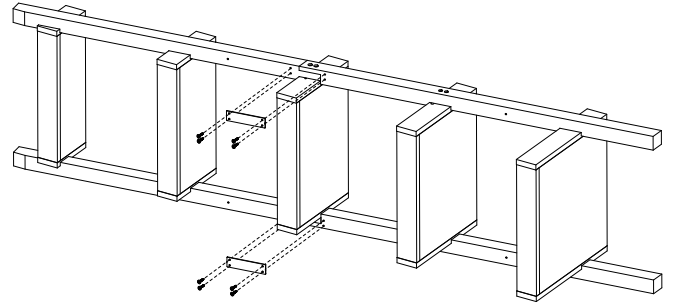
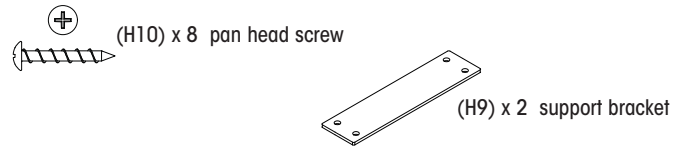

1. Locate the pilot holes (as shown) for the support brackets (H9) on the backs of the legs.
2. Use the pan head screws (H10) to attach the support brackets to the back of the units.

Step 5

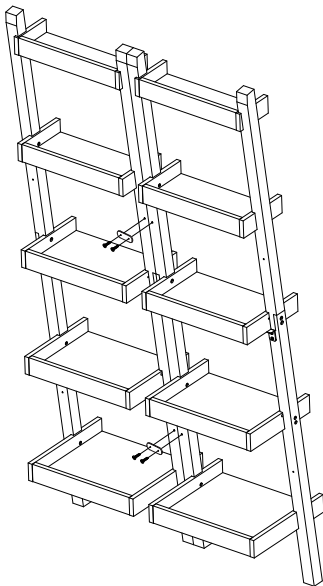

1. If you purchased multiple units, use the mending plates to connect them.
2. Locate the pilot holes (as shown) on the backs of the legs.
3. Use the small flathead screws (H8) to attach the mending plates (H7) to the back of the units.

Step 6

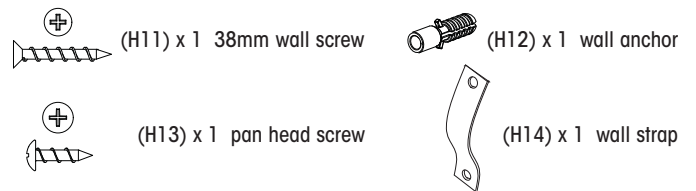

⚠ This product must always be mounted to a wall. It is essential to use wall anchors appropriate to your wall type (e.g., plaster, drywall, etc.). If you are unsure about your wall type or which mounting method to use, consult a qualified professional. These directions are for installation into drywall; however, you should mount to wood studs whenever possible.

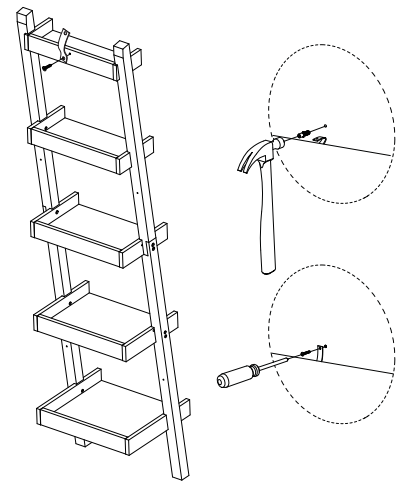

1. Locate the pilot hole and attach the wall strap (H14) to the back of the shelf with the pan head screw (H13).
2. Position the unit against the wall in the desired location.
3. Mark the position of the strap hole on the wall.
4. Drill a 17/64" hole.
5. Tap in the wall anchor (H12).
6. Fasten the wall strap with wall screw (H11).

Weight Limit Warning

⚠ Do not exceed the recommended weight limits on the designated shelves. Exceeding these limits can cause sagging, possibly resulting in shelf failure or bodily injury.

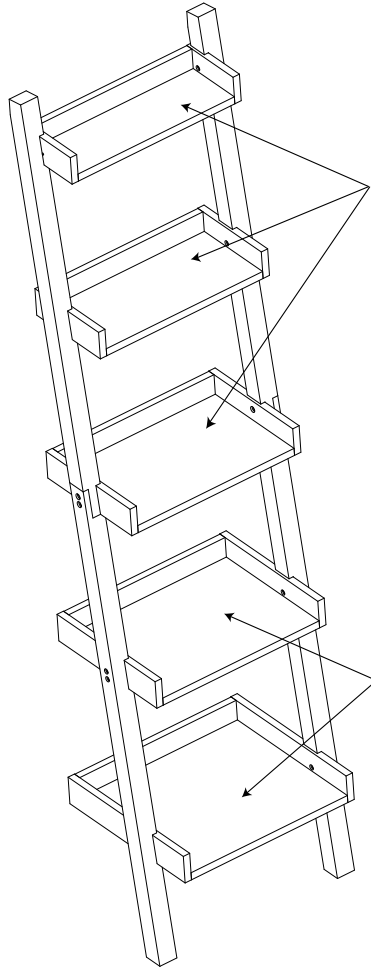

Top three shelves hold up to 50 pounds each.

Lower two shelves hold up to 75 pounds each.