

elfa[®]

Instructions for Easy Installation & Assembly

The Container Store[®]

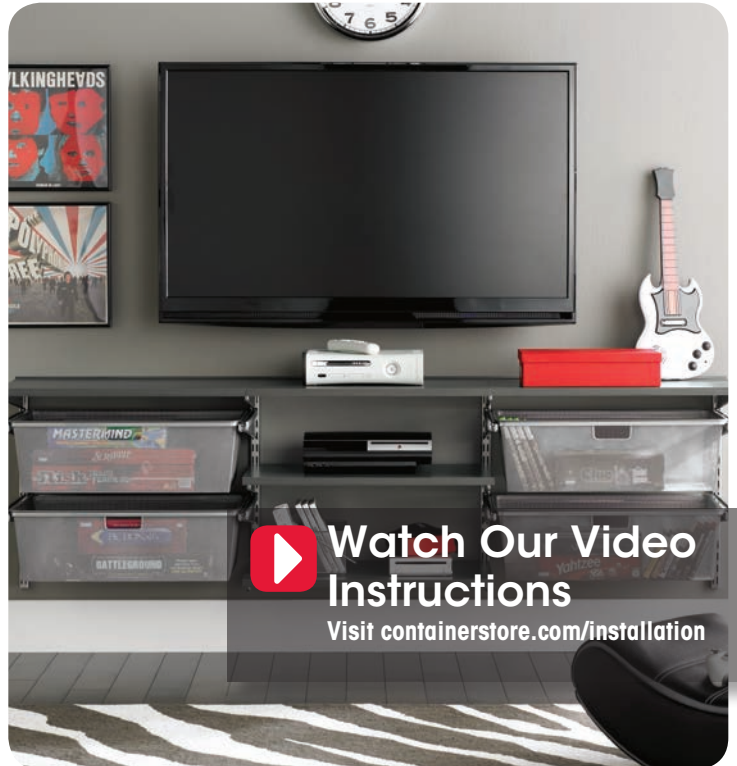

Watch Our Video
Instructions

Visit [containerstore.com/installation](https://www.containerstore.com/installation)

Quick Reference Guide

- **Hardware, Top Track and Hanging Standards** pages 2-4
- **elfa freestanding®** pages 5-8
- **Classic Hanging Drawers, décor Drawers and Gliding Accessory Racks** pages 8-9
- **décor Shelves** page 10
- **Ventilated Shelves** page 10
- **décor Fascia** page 11
- **Closet Rods** page 11
- **Solid Shelving** pages 12-14
- **Wall-Mounted Standards** page 15
- **elfa Drawer Units** page 16

If at any time during installation you have questions, call the store listed on your receipt or **800-733-3532**. You may also visit containerstore.com/installation to view video instructions.

A



Wood Screw

B

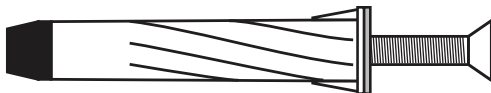

Drywall & Plaster Anchor

C



Sheet Metal Screw

D



Concrete Screw

TIPS for getting started

- Remove all contents from your space and donate or sell all items no longer needed.
- For closets, hang clothes that you are keeping on a garment rack outside the closet during installation.
- Take out any old shelving and/or closet rods. Patch and repaint walls.
- Tape the page(s) of your custom elfa design to the corresponding wall.
- Refer to your design for placement of your elfa. Lay out all the products by type, size and wall.

Hardware, Top Track and Hanging Standards

Tools needed: pencil, level, power drill, drill bit set, #2 Phillips head bit for power drill, #2 Phillips head screwdriver, hammer, tape measure, ladder or step stool, elfa 2' spacer, plastic mallet, scissors.

STEP 1 Hardware

Based on what you have told your designer, you have been provided with the correct hardware needed to complete the installation based on your wall construction. Below are instructions for installing each type of hardware:

Wood Screw (Figure A)

Used for mounting the Top Track into drywall over **wood studs** or **directly into wood**.

- Drill a hole with a 1/8" drill bit the length of the drill bit.

TIP

- Rake the wood screw over a bar of soap before inserting it into the wall. This will make tightening the screw easier.

Drywall & Plaster Anchor (Figure B)

Used for mounting the Top Track into **1/2" drywall** (most common wall type) or **5/8" to 1" drywall/plaster**.

- Enlarge the hole with a 3/8" drill bit.
- Remove the screw from the white anchor, ensuring the gray insert stays in place.
- Tap the anchor into the hole with the plastic mallet.
- Discard the grey spacers that are included in the packaging (not shown).

Sheet Metal Screw (Figure C)

Used for mounting the Top Track into drywall over **sheet metal studs**.

- Drill a hole with an 1/8" drill bit the length of the sheet metal screw.

Concrete Screw (Figure D)

For **concrete/ masonry (cinder block or brick)**, drill a hole with a 5/32" masonry drill bit the length of the concrete screw.

For **masonry with furring***, drill a hole with a 5/32" masonry drill bit the length of the concrete screw.

* Furring is a space usually 3/4" between the drywall and masonry surface. Furring strips are 1" x 2" pieces of wood attached to the masonry. The drywall is attached to the furring strips. When possible, the Top Track should be installed over the furring strip.

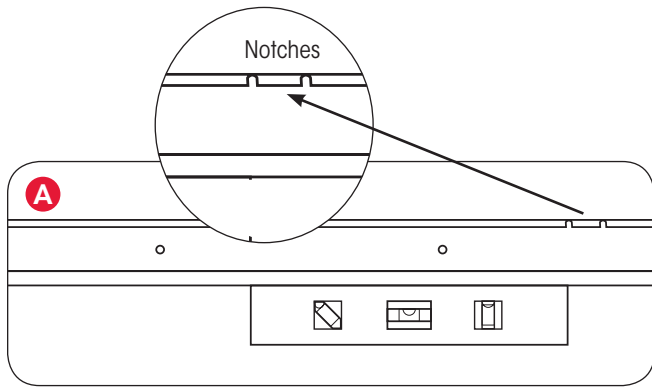

TIP • Top Tracks have a top and a bottom. The **TOP** is designated on the label and has **two notches** to allow Hanging Standards to be inserted properly. (Figure A)

STEP 2 Level the Top Track

- Place the Top Track at desired height (refer to your design). Place the level at the bottom of the Top Track to ensure it is straight. (Figure A)

TIP • For longer Top Tracks, drill the center hole and secure with one screw. Tighten the screw enough to hold the Top Track against the wall while leveling and marking the rest of the holes.

- While leveling your Top Track, mark all the holes with a pencil.
- Set the Top Track aside, then drill all marked holes with a 1/8" drill bit. (Figure B)
- If you hit wood, continue drilling the entire length of the drill bit.
- In most applications, you will not hit wood for every hole. If you find you've hit the hollow part of the wall, mark that hole with a small "X." (Figure B)
- The "X" is to remind you, after drilling all holes, to go back and enlarge that hole with the appropriate drill bit size for the hardware needed for your wall construction (see page 2).

STEP 3 Install the Top Track

TIP • Be careful not to drill into any electrical wires, ductwork, plumbing or other damageable components. If you have any questions on the locations of these wires or lines, please contact a professional electrician or plumber before drilling.

- Place the Top Track on the wall and insert and tighten all the screws using a power drill with a #2 phillips head bit. (Figure C)
- To avoid stripping the screw, finish hand tightening with a #2 Phillips head screwdriver.
- In order for the wall anchors to be secure, it is important to **HAND** tighten the screw until it stops turning.
- It is important **NOT** to overtighten, because this may result in a stripped screw.

Continued on page 4

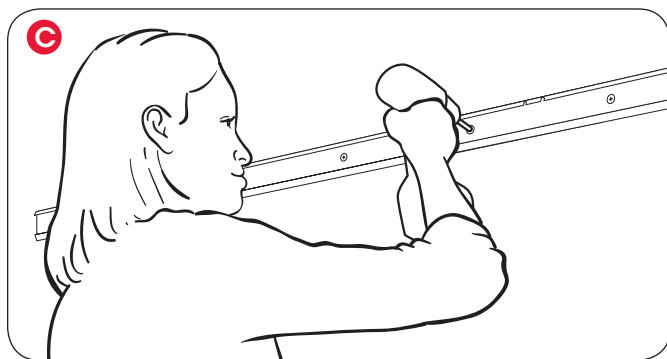

The Container Store® Installation Service Let Us Do the Work for You!

Our time-saving Installation Service is available in all stores. Visit [containerstore.com/installationservice](https://www.containerstore.com/installationservice) for details.

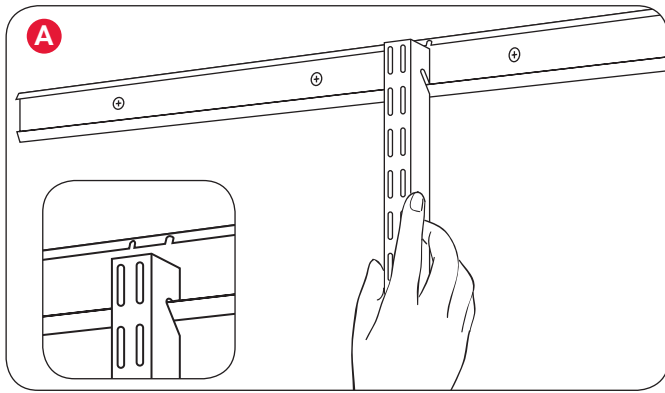

STEP 4 Install the Hanging Standards and Shelf Brackets

- Insert the Hanging Standards in the Top Track notches. **(Figure A)**
- Group Hanging Standards together and insert Brackets at the appropriate height based on your space plan. **(Figure B)**
- Slide the Hanging Standards to their approximate position on the Top Track. Refer to your design for placement of the Hanging Standards.
- **Hanging Standards should be a minimum of 1/2" from the ends of the Top Track.**

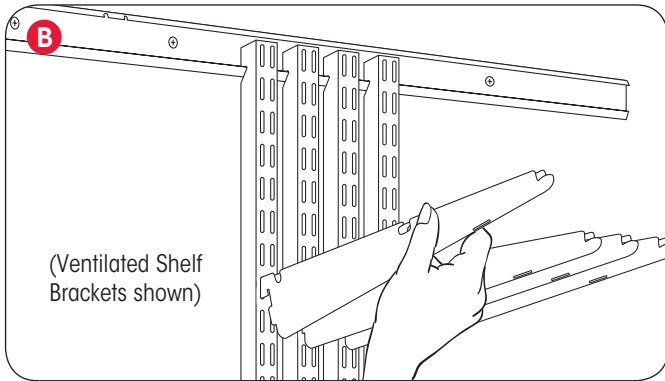

You are now ready to install other elfa components. Please refer to your design and the Quick Reference Guide on page 2 for component-specific instructions.

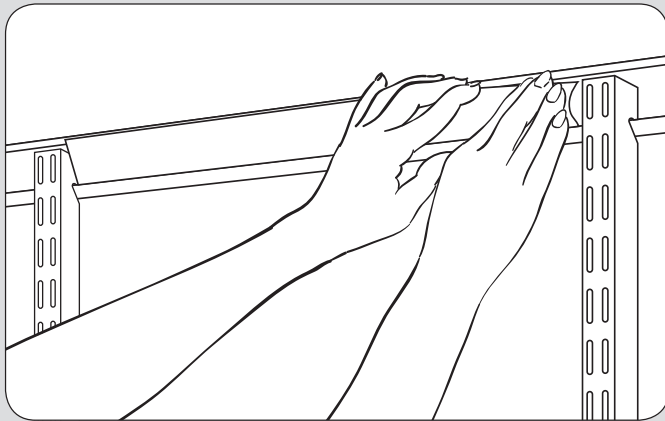

Top Track Cover Installation

- You should install your Top Track Cover after you have completed all the installation steps in this booklet.
- Start with long pieces first. Place the bottom of the Top Track Cover into the bottom of the Top Track, then ease the top of the Top Track Cover into the top of the Top Track.
- Measure the area on the Top Track where smaller pieces of the Top Track Cover are needed.
- Measure and mark the Top Track Cover where the cuts need to be. The Cover is easily cut in a straight line with scissors.
- Do not overlap segments of the Top Track Cover.

The Container Store®

Installation Service

Let Us Do the Work for You!

Our time-saving Installation Service is available in all stores. Visit [containerstore.com/installationservice](https://www.containerstore.com/installationservice) for details.

elfa freestanding

Tools needed: plastic mallet, ladder or step stool for 62" and 83" tall solutions

TIPS for getting started

- It's best to have two people to assemble a 62" or 83" tall solution.
- Please note that any solution used away from the wall requires feet on both sides of the solution.
- If you have Foot Height Extenders, add them before proceeding. To install, unscrew both levelers from the Foot and screw the extenders directly into base of the Foot. The levelers can then be screwed into the Foot Height Extenders and adjusted as needed to accommodate baseboards between 2" to 4".
- If assembling on tile or wood, take care to protect the floor.

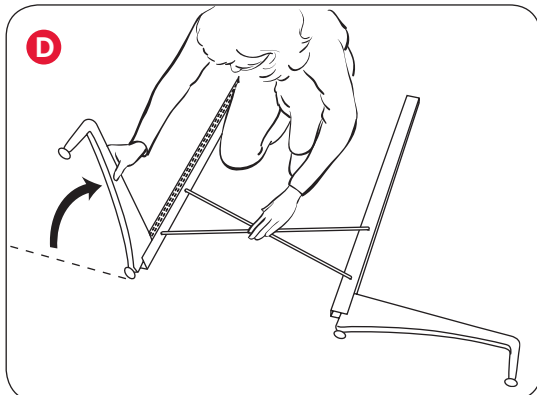
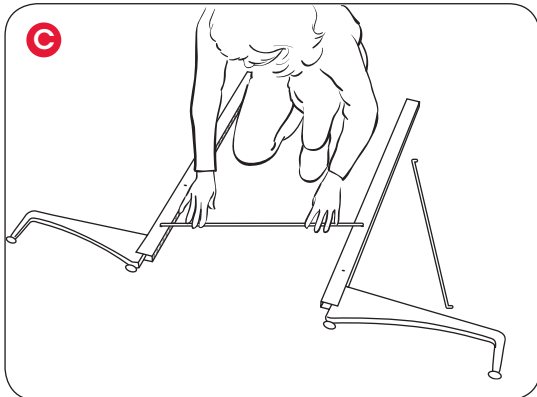
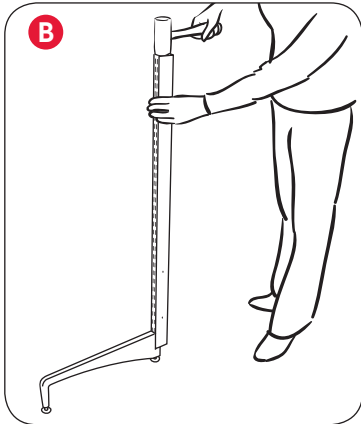
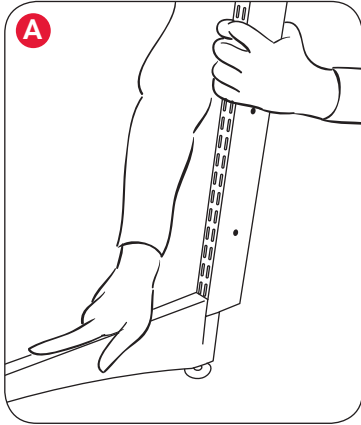

Assemble a Single - Sided Solution

STEP 1 Insert Upright into Foot

- The holes on the side of the Upright indicate the bottom of the Upright. There is no front or back to the Uprights.
- Line up the Upright with the slot in the Foot. **(Figure A)**
To secure, you can tap the Upright and Foot together on the ground or use the mallet. Make sure the Upright is all the way into the slot on the Foot. **(Figure B)**
- Repeat with a second Upright and Foot.

STEP 2 Install Crossbraces

- Place the assembled Uprights/Feet on the floor as shown. **(Figure C)**
- Insert Crossbraces diagonally into holes at bottom of the Uprights. **(Figure C)**
- Gently hold the Crossbraces at the center with one hand. Using your other hand, lift one Foot so that it faces up, then lift the other Foot. **(Figure D)**

Continued on page 6

STEP 3 Install Stabilization Bar

TIP

- When assembling a 62" or 83" unit, use a ladder or step stool to reach the top of the solution. Another person should hold the Uprights in place as you tap the Stabilization Bar into the top of the Uprights.

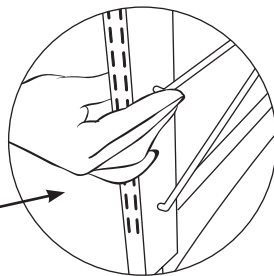
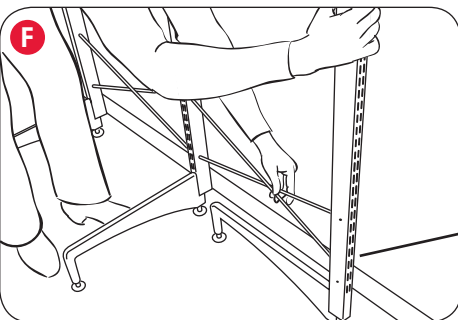
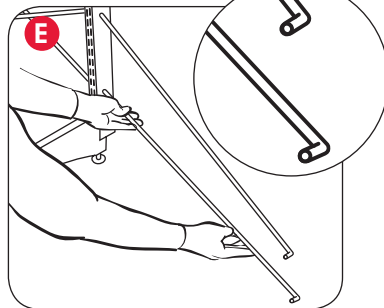
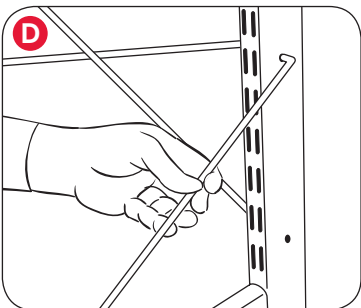
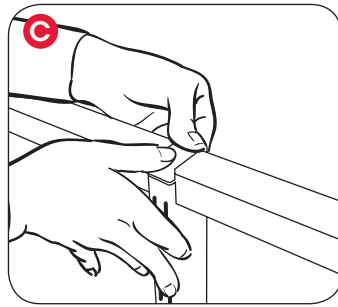
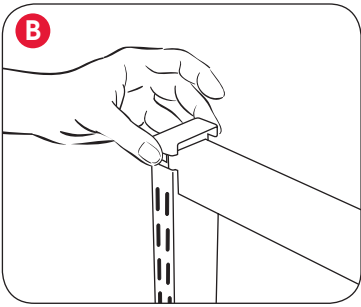
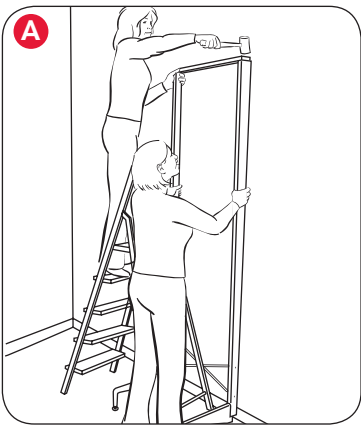

view from back

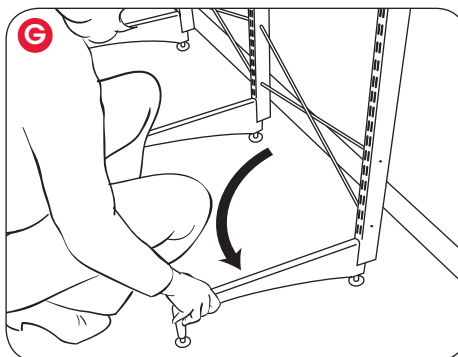

- Stand the unit upright and position it at the desired location against the wall.
- Secure the Stabilization Bar by tapping both ends into the top of the two Uprights with the plastic mallet. (Figure A)
- Alternate tapping left and right ends until both are locked into place.

If assembling a 4' or wider solution, proceed to the next section.

- If assembling an 18", 2' or 3' wide solution, you can now add End Caps (included) to the top of the Uprights for a finished appearance. (Figure B)

Add a section to a Single - Sided Solution

- Insert Upright into Foot as directed on the previous page.
- Insert one Crossbrace into the top hole on the side of the Upright to the completed section (Figure D); insert the other Crossbrace into the bottom hole. The bent tips on the unattached end of each Crossbrace should point forward. (Figure E) For an 18" section, the bent tips on the unattached end of each crossbrace should point backward.
- Position the third Upright so that the Foot points toward the already completed section. (Figure F) For an 18" section, position the third Upright so the Foot points away from the completed section.
- Insert the unattached ends of the Crossbraces diagonally into the third Upright. (Figure E) Pull the third Upright back to the forward position (so that the Foot is facing forward.) This locks the Crossbraces into place. (Figure G)
- Add the Stabilization Bar as shown in Step 3 above. Tap the Stabilization Bar into the shared Upright first, then the third Upright.
- Alternate tapping the left and right ends of the Stabilization Bar until both are locked into place.
- Repeat this process for additional sections.
- Add End Caps and Center Cap(s) (included) at the top of the Upright for a finished appearance. (Figure B, Figure C)

Refer to your design for placement of the elfa Brackets on the freestanding Uprights.

Once you've added all elfa components, adjust levelers as needed with the wrench included with the Feet.

Assemble a 2' or 3' Double - Sided Solution

Tools needed: plastic mallet, ladder or step stool for 62" and 83" tall solutions

TIPS for getting started

- It's best to have two people to assemble a 62" or 83" tall solution.
- Before you begin, make sure the levelers on each Foot are screwed all the way into the Foot.
- Please note that all double-sided solutions require Feet on both sides of the solution.
- If assembling on tile or wood, take care to protect the floor.

STEP 1 Insert Upright into Feet

- The two holes on the side of the Upright should be at the bottom of your finished solution.
- Line up the Upright with the slot in the Foot. **(Figure A)** To secure, you can tap the Upright and Foot together on the ground or use the mallet. Make sure the Upright is all the way into the slot on the Foot. **(Figure B)**
- Repeat this process with another Foot on the opposite side of the Upright. Set aside. **(Figure C)**
- Repeat the above three steps with another Upright and two Feet.

STEP 2 Install Crossbraces

- Insert one Crossbrace into the top hole on the side of the Upright; insert the other Crossbrace into the bottom hole. The bent tips on the unattached end of each Crossbrace should face the same direction. **(Figure D)**
- Position the second assembled Upright/Feet set so that it is perpendicular to the first set. **(Figure E)**
- Attach the opposite ends of Crossbraces diagonally into the holes of the second Upright. **(Figure E)**
- Pull the second Upright/Feet set back to the forward position (so that the Feet on both sides of the solution are parallel). This will lock the Crossbraces into place. **(Figure F)**

For an 18" Double - Sided Solution, follow the instructions for a Single - Sided Solution, on page 5. When the Solution is assembled, tilt the unit until you can line up the Uprights with the slots in the Feet. Tap into place.

Continued on page 8

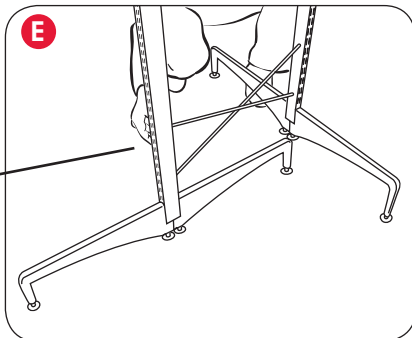
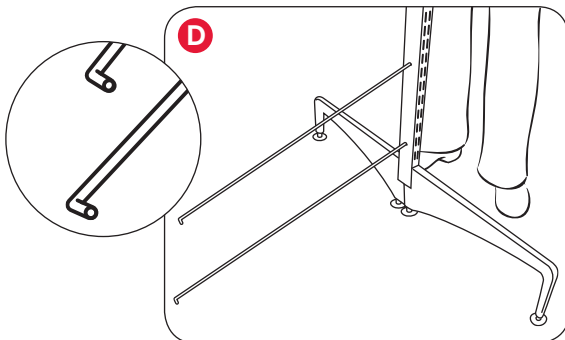
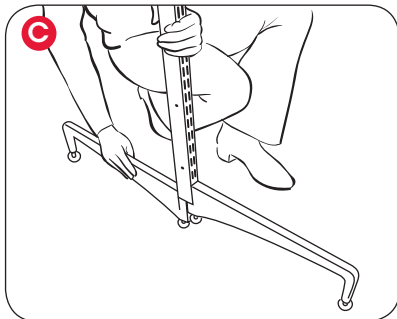
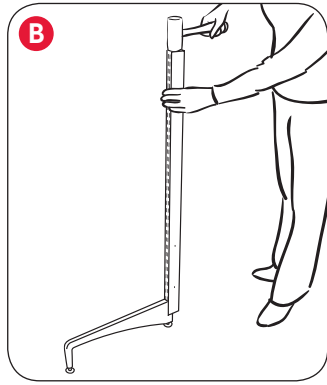
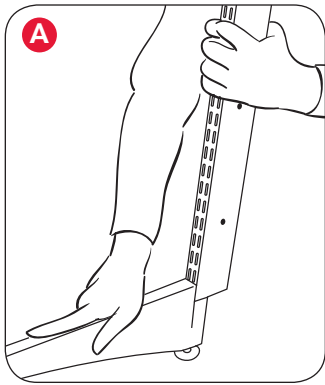

view from back

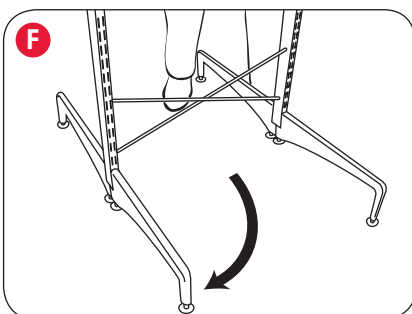

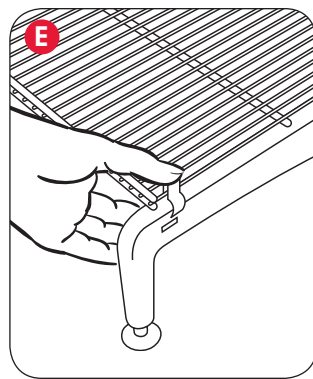
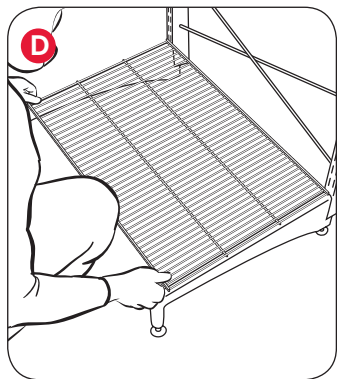
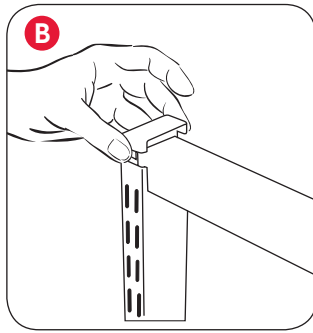
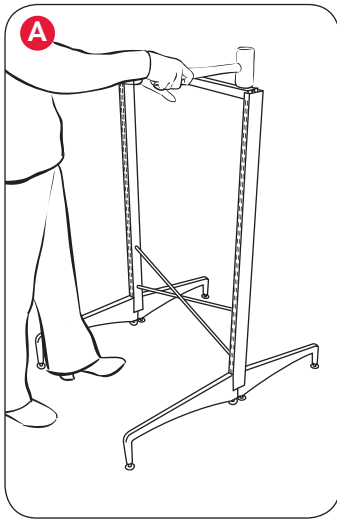

STEP 3 Install Stabilization Bar

- Secure the Stabilization Bar by tapping both ends into the top of the two Uprights with a plastic mallet. (Figure A)
- Alternate tapping left and right ends until both are locked into place.
- Add End Caps (included) at the top of the Uprights for a finished appearance. (Figure B)

If assembling 4' or wider solution, repeat above Steps 1, 2 and 3 as necessary. After all of the sections are added, place End Caps and Center Caps (included) at the top of the Uprights for a finished appearance. (Figure B, Figure C)

STEP 4 Attach a Ventilated Shelf to the Feet

- Lay the Ventilated Shelf across the span between the Feet. The support wires should run along the bottom of the Shelf.
- Place the last Shelf wire over the middle of each Foot. (Figure D)
- Start at the back of the Shelf. Slip the Shelf Clip over the last Shelf wire; it will snap into the notches on both sides of the Foot.
- Repeat for all four corners of the Shelf. (Figure E)
- If your design calls for two Shelves to share one Foot, begin by attaching the clips at the joined Shelves first, then clip the opposite ends of both Shelves.

Refer to your design for placement of the elfa Brackets on the freestanding Uprights.

Once you've added all elfa components, adjust levelers as needed with the wrench included with the Feet.

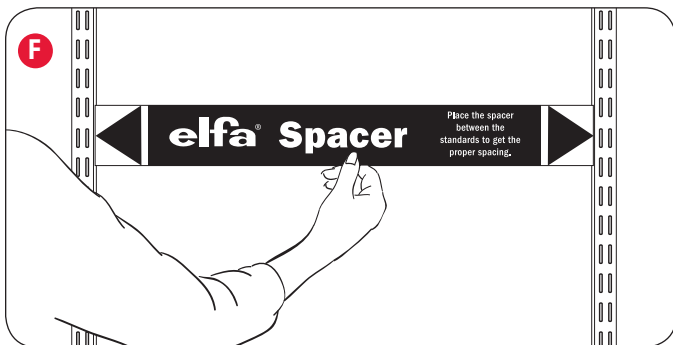

Classic Hanging Drawers, décor Drawers and Gliding Accessory Racks

These components must be installed before installing Ventilated Shelves.

STEP 1 Place Hanging Standards

- Hanging Standards should be positioned using the elfa Spacer provided in the package (Figure F) according to your design.

STEP 1 Install the U-Shaped Metal Glides

TIP

- Gliding Accessory Racks, elfa Classic Hanging Drawers and décor Drawers are all installed with the same U-Shaped Metal Glide.
- If you would like more space between the gliding components, simply move them to the desired position.

The U-Shaped Metal Glide has three metal tabs and a metal knob on each side (located at the top of the glide) that locks the glide into the Bracket.

- Begin with the left Bracket. Align the metal tabs on the U-Shaped Metal Glide with the cutout notches of the Bracket. **(Figure A)**
- Once aligned, hold the front of the Bracket and press on the U-Shaped Metal Glide at the back rounded corner until you hear it lock into place. **(Figure A)**
- Repeat on the right side.

TIP

- **To REPOSITION the U-Shaped Metal Glide:** It is not necessary to remove the glide from the Brackets. Simply tilt up the front of both Brackets and remove them from the Hanging Standards. Place in the desired location.
- **To REMOVE the U-Shaped Metal Glide from the Brackets:** Place one hand at the back of the glide. With your thumb on the Hanging Standard, gently push the glide forward with your fingers. At the same time, insert and twist a small flat head screwdriver between the Bracket and U-Shaped Metal Glide in front of the knob holding the glide in place. The U-Shaped Metal Glide should pop out of the Bracket. Repeat on the other side. **(Figure B)**
- Gliding accessories that are side-by-side will share a Bracket at the center.

STEP 2 Install the Gliding Accessories

- Align the rollers on each side of the frame with the openings in the U-Shaped Metal Glide. Slide the frame into the glide. **(Figure C)**

Drawers

- Always start with the bottom Drawer and work up.
- For décor Drawers, insert the Drawer into the frame opening and attach it to the left and right side of the wood frame with the provided Drawer Clips. **(Figure D)**
- For Classic Hanging Drawers, simply insert the Drawer into the frame opening.

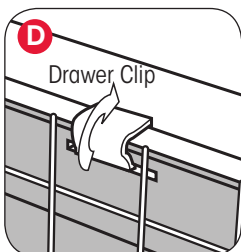
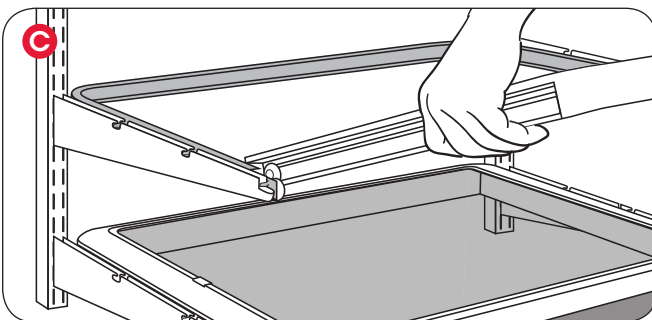
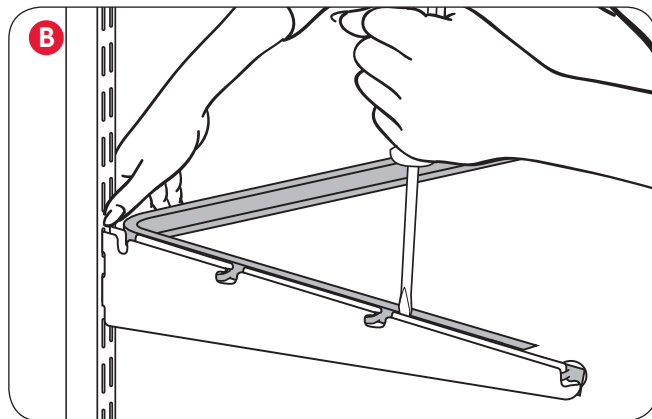
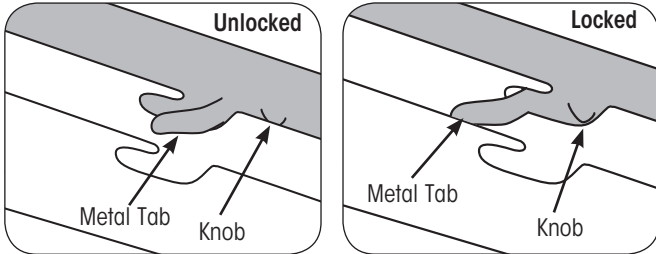
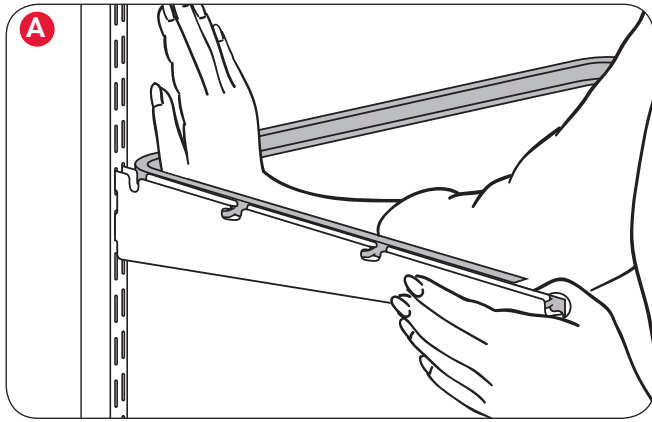

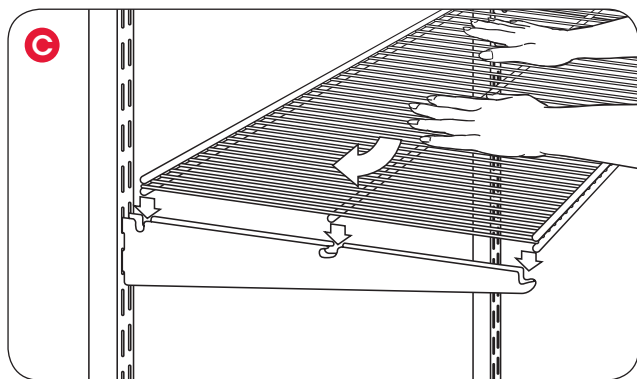
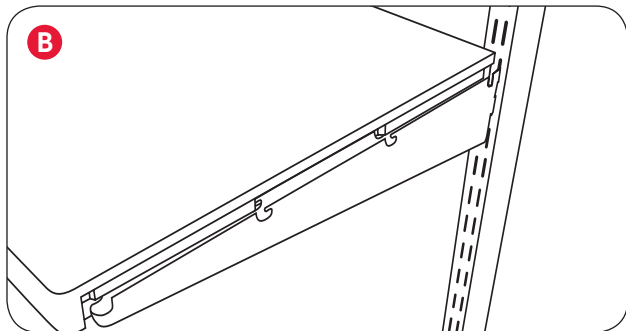
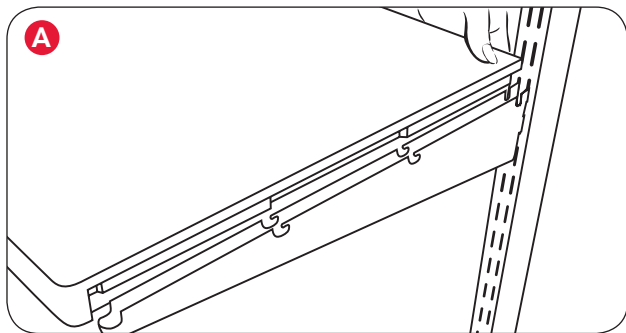

décor Shelves

- Insert Ventilated Shelf Brackets into the Hanging Standards at the desired height.
- Place the décor Shelf over the Brackets (Figure A) and press down to snap into place. (Figure B)

Ventilated Shelves

STEP 1 Install the Ventilated Shelves

- TIP**
- Install the Ventilated Shelves from shortest to longest, regardless of their location in the space.
 - Ventilated Shelves have a top and a bottom. The middle support wire(s) is connected to the bottom of the Shelf.

- Place the Shelf wires over Shelf Bracket notches.
- Install the Shelf with end wires inside the Brackets.
- Lock the Shelf into place by pressing down on the middle of the Shelf and pushing toward the wall. (Figure C)

- TIP**
- **To REPOSITION a Ventilated Shelf after it's been attached to the Brackets:** Hold by the Brackets, and lift the front of the shelf toward the ceiling and outward to release the entire unit from the Hanging Standards. (Works on all Shelves except 20" depth.)
 - **To REMOVE a Ventilated Shelf from a Bracket while on the Hanging Standards:** Hold the Hanging Standard steady with one hand. Place the other hand at the back of the Shelf. Pull up and forward to release.

STEP 2 Install the Shelf Baskets (not shown)

- With the double wire front lip of the Shelf Basket facing forward, place the Shelf Basket wires over the Shelf Bracket notches.
- Install the Shelf Basket with the end wires inside the Bracket.
- Lock the Shelf Basket into place by pressing down on the middle of the Shelf Basket and pushing toward the wall.
- Insert Shelf Basket Dividers where desired, if applicable.

STEP 3 Install the Shelf Basket Fascia (not shown)

- Position the Shelf Basket fascia underneath your Shelf Baskets with the curved edges of the Shelf Basket fascia face down and parallel to the floor.
- Lift the Shelf Basket fascia up to the underside of the front edge of the installed Shelf Baskets and push back towards the wall until it clips into place.

The Container Store®

Installation Service

Let Us Do the Work for You!

Our time-saving Installation Service is available in all stores. Visit [containerstore.com/installationservice](https://www.containerstore.com/installationservice) for details.

décor Fascia

TIP

- Add Shelf Liners before installing Fascia.
- Position ALL pieces of Fascia before installing clips.

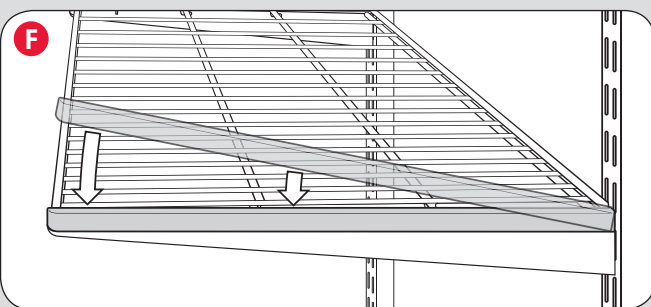
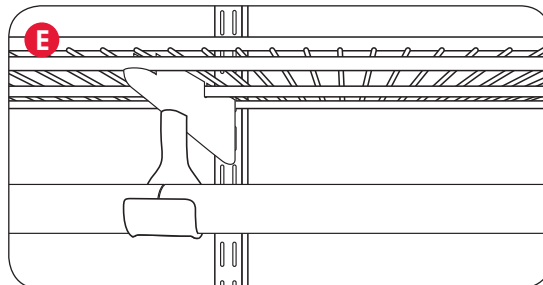
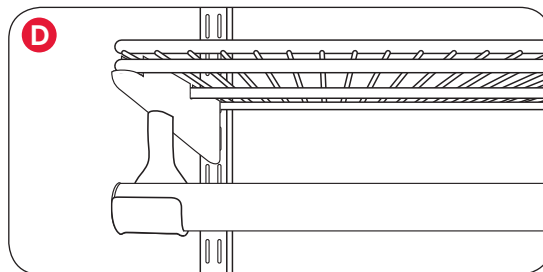
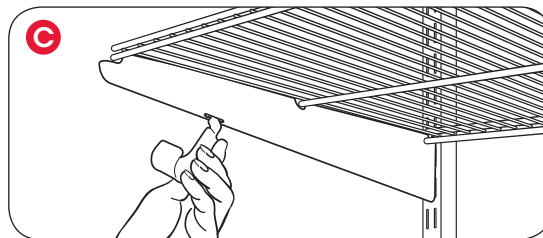
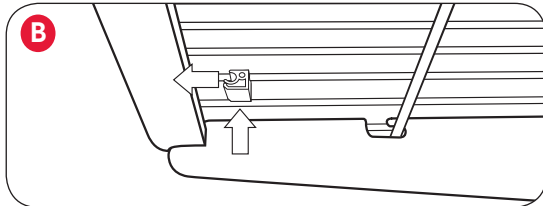
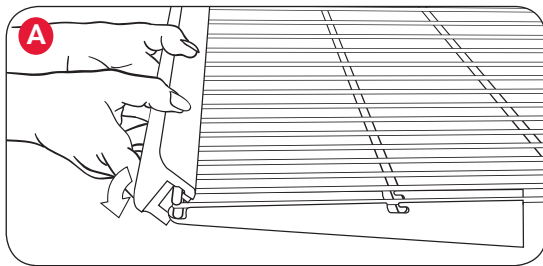

- Position the Fascia with the opening facing the Ventilated Shelf. **(Figure A)** The notch in the Fascia that hooks onto the front support wires of the Ventilated Shelf should be at the top. Hook over the top wire with a downward motion, and secure it to the front of the Shelf.
- Use the included clips to secure the Fascia to the Ventilated Shelf.
- The top of the clip features a groove that accommodates one shelf wire. Once it's attached to the underside of a shelf wire, slide it all the way to the front of the Shelf and into the opening of the Fascia for a secure hold. **(Figure B)**
- Repeat with another clip at the opposite end of the Fascia. If you are installing a 1-1/2' or 2' Fascia, add the third clip at the center of the Fascia.

Closet Rods

STEP 1

Install the Closet Rod Holders and Closet Rods

- Insert the Closet Rod Holder into the slot in the bottom of the Ventilated Shelf Bracket. **(Figure C)**
- Tap the End Caps into both ends of the Closet Rod.
- Snap the Closet Rod into the Closet Rod Holder. **(Figure D)**

STEP 2

Installing Closet Rods that Share a Closet Rod Holder

- First, install joined rods in the center of the Closet Rod Holder, then place the outer ends in the Closet Rod Holder. **(Figure E)**
- Tap the End Caps only into the non-joined ends of each Closet Rod. Adding End Caps to the joined ends creates a gap.

Install the Bracket Covers

- Left and Right Bracket Covers are not interchangeable.
- Place the outer edge of the Bracket Cover over the outer edge of the Ventilated Shelf Bracket. **(Figure F)**
- Push down from the back to the front to snap the Bracket Cover in place.

Solid Shelving

TIP

- There are pre-drilled holes on the bottom of the Shelf for ease of installation.
- The row of Shelving closest to the middle should be installed first. **(Figure A)**
- Group Shelves by color: 30" Shelves have a blue sticker; 25" End Shelves have a green sticker; 24" Center Shelves have a red sticker. The sticker also indicates the front of the Shelf.

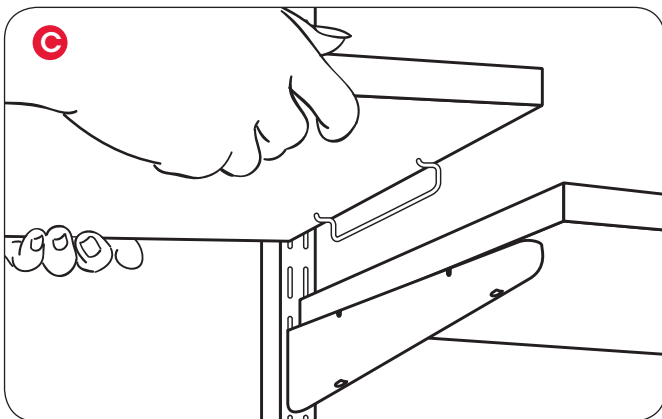
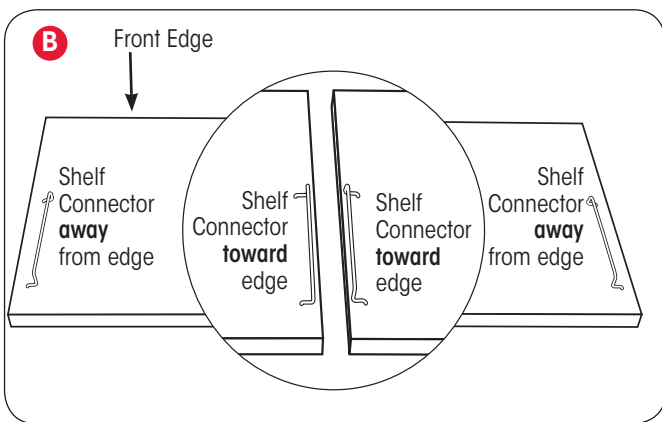
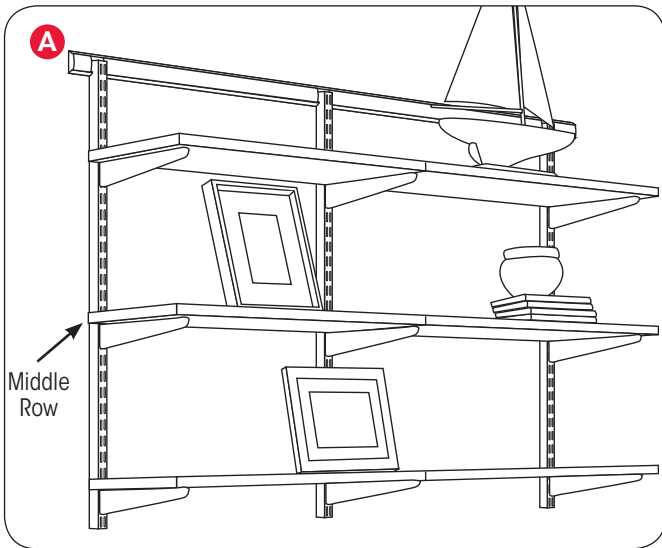

Install Connected Shelves

(Figure A)

- STEP 1**
- Flip the Shelf upside down to expose the holes with the back of the Shelf toward you.
 - Insert the Shelf Connectors as shown. **(Figure B)**
- STEP 2**
- Flip the Shelf right side up and place the Shelf Connectors into the Bracket notches. Connected Shelves share a Bracket. **(Figure C)**
 - After installing the middle row of shelving, repeat for each row of Shelves.

Install Independent Shelves with Connected Shelves

(Figure A)



- STEP 1 – Flip the Shelf upside down to expose the holes, with the back of the Shelf toward you.
- STEP 2 – Insert Independent Shelf Pins with the arrow to the outside edge of the Shelf.
- STEP 3 – Flip the Shelf right side up and place the Independent Shelf Pins into the Bracket notches. (Figure B)

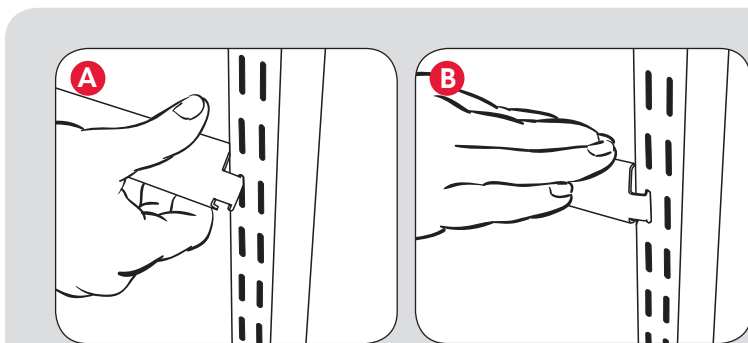
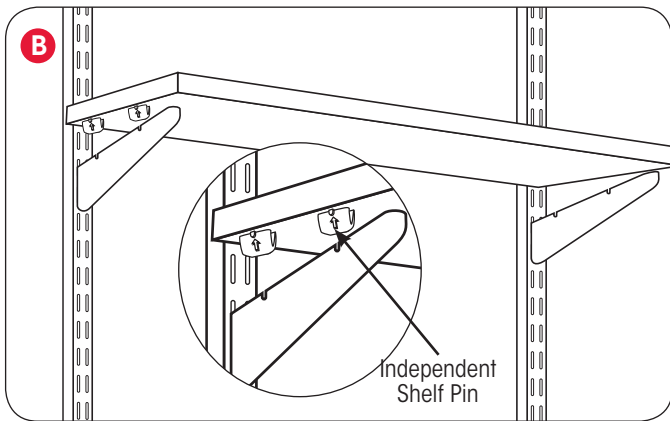

Install a Back Stop Bar

- Holding the Back Stop Bar at a slight angle, slide the top tabs of the Back Stop Bar up into the Hanging Standard or freestanding Upright. (Figure A)
- Press the Back Stop Bar down to lock it in place. (Figure B)

The Container Store®

Installation Service

Let Us Do the Work for You!

Our time-saving Installation Service is available in all stores. Visit containerstore.com/installationservice for details.

Install a Single Section of Shelving (Figure A)

- TIP**
- There are drilled holes on the bottom of the Shelf for ease of installation.
 - The row of shelving closest to the middle should be installed first. (Figure A)

- STEP 1** – Flip the Shelf upside down to expose the holes with the back of the Shelf toward you.
- Insert the Shelf Connectors as shown. (Figure B)
- STEP 2** – Flip the Shelf right side up and place the Shelf Connectors into the Bracket notches.
- Repeat for the remaining Shelves.

Install Using Shelf Screws

(not shown)

Additional tool needed: awl (or similar pointed tool)

- TIP**
- Shelf Screws are an alternative to using Shelf Connectors. They are used with Desk Tops and on rare occasions with Solid Shelves when it is necessary for the Shelves to remain fixed.

- STEP 1** – Place the Desk Top on the Brackets and use a pencil to trace an outline of the Brackets.
- STEP 2** – Take the Desk Top off the Brackets and flip it upside down on a solid surface with the pencil marks visible.
- STEP 3** – Take a Bracket out of a Hanging Standard to use as a guide. Place the Bracket over each Bracket outline on the Desk Top and use an awl to punch a mark for the screws through each hole in the Bracket. Be sure to keep the awl straight.
- STEP 4** – Remove the Bracket and use a 1/8" drill bit to drill a hole at each punch mark.
- STEP 5** – Place the Desk Top on the Brackets and align the holes in the Shelf with the corresponding Shelf Bracket holes.
- STEP 6** – Insert the shorter screw in the front hole and the longer screw in the back hole of each Bracket.
- Tighten each screw with a #2 Phillips head screwdriver.

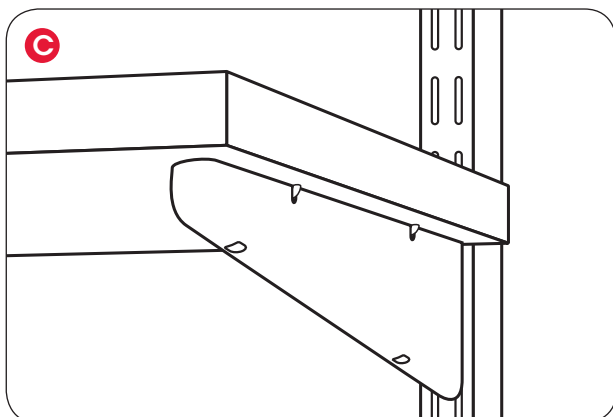
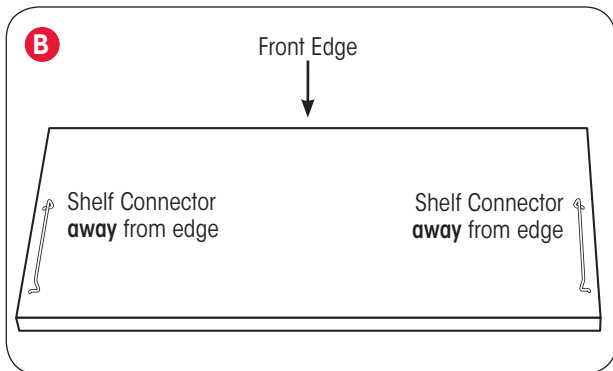
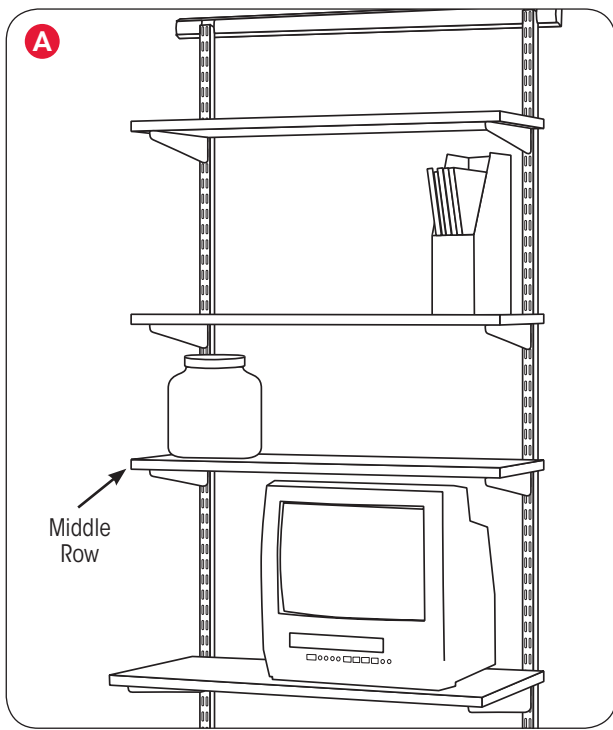

Wall-Mounted Standards

Tools needed: level, power drill, drill bits, #2 Phillips head bit for a power drill, hammer, plastic mallet, ladder or step stool

TIP

- **Mounting Standards in a Corner:** Install the Standard approximately 2" from the corner to allow enough room for the drill or screwdriver.

- STEP 1**
- Position one Standard where you want it on the wall.
 - Mark the position of the second screw hole from the top of the Standard.
- STEP 2** **Drywall & Plaster Anchor with Spacer (Figure A)**
- Used for mounting the Standards into **1/2" drywall** (most common wall type) or **5/8" to 1" drywall/plaster**
- Enlarge the hole with a 3/8" drill bit.
 - Remove the screw from the white anchor; remove and discard the grey insert.
 - Add the grey spacers included in the packaging to the white anchors.
 - Use a plastic mallet to gently tap the anchor (with spacer) so the top of the anchor is flush with the wall.
- STEP 3**
- Using a level, check that the Standard is straight.
- STEP 4**
- Mark and drill the remaining holes and install all of the screws and necessary anchors.
- STEP 5**
- To install the next Standard, measure and mark out a suitable distance between the two Standards, based on your custom design.
- STEP 6**
- While holding the unattached Standard to the wall, place a Shelf on the Brackets. Adjust the spacing as needed and check that the Shelf is level. **(Figure B)**
- STEP 7**
- Mark, then drill, the remaining holes and screw the second Standard into place as in Step 2. Repeat for each Standard.

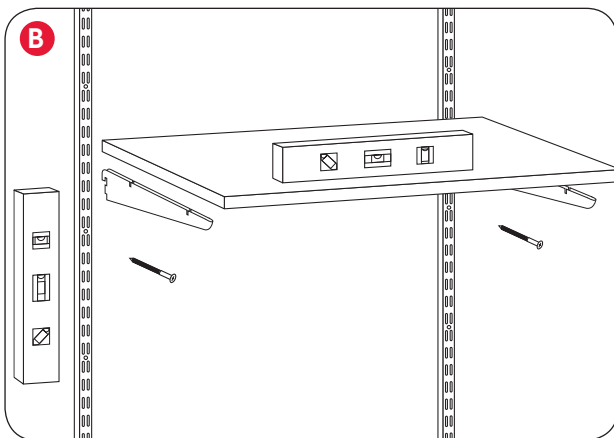
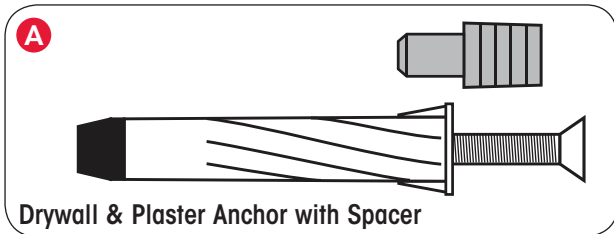

The Container Store®

Installation Service

Let Us Do the Work for You!

Our time-saving Installation Service is available in all stores. Visit [containerstore.com/installationservice](https://www.containerstore.com/installationservice) for details.

elfa Drawer Units

Assemble a Single Frame

Tools needed: plastic mallet

TIPS for getting started

- If you don't have a plastic mallet, you can use a hammer with a wood block to protect the frame.
- If assembling on tile or wood, take care to protect the floor.

- STEP 1** Position the Side Panels with the runners facing inward. (Figure A)
- STEP 2** Using a plastic mallet, tap the Bottom T-Crossbars into the bottom of each Side Panel.
- STEP 3** Put a Back Stop Pin in the back holes of the top runners. The remaining Back Stop Pins should be put in place just prior to sliding in the Drawers.

If combining Frames, see instructions below.

- STEP 4** **If using a Melamine Top**, tap the Top L-Crossbars completely into each Side Panel. Place adhesive strips included in the packaging on the top L-Crossbars. Align the Melamine Top with the crossbars and press firmly.

If not using a Melamine Top, tap the Top L-Crossbars completely into each Side Panel.

Combine Frames

- STEP 1** Assemble the top Frame completely. (See Steps 1 and 2 above.)
- STEP 2** Assemble the bottom Frame, omitting the Top L-Crossbars.
- STEP 3** If using Back Stop Pins, put one in the back of the left and right top runners of the bottom Frame.
- STEP 4** Lower the top frame onto the bottom frame, making sure the Back Stop Pins are all on the back side. Secure by firmly tapping each corner of the top frame until Bottom T-Crossbars are completely inserted into the bottom frame. (Figure B)

Insert Drawers

- STEP 1** Insert the remaining Back Stop Pins.
- STEP 2** Slide in the Drawers.
- STEP 3** If you have other elfa Frame and Drawer accessories, add them now.

